

DTM

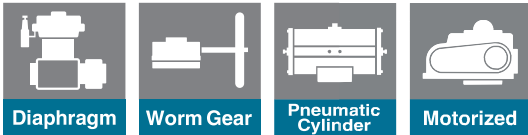

General Description

The Ultimate Rotary Control DTM provides high accurate control under most critical process conditions including higher pressure drop liquid/gas applications. DTM series valves can be supplied with or without integrated cavitation breaker in order to reduce noise level by max. 30 dB. Valves in this series also exhibit higher anti-cavitation capability.

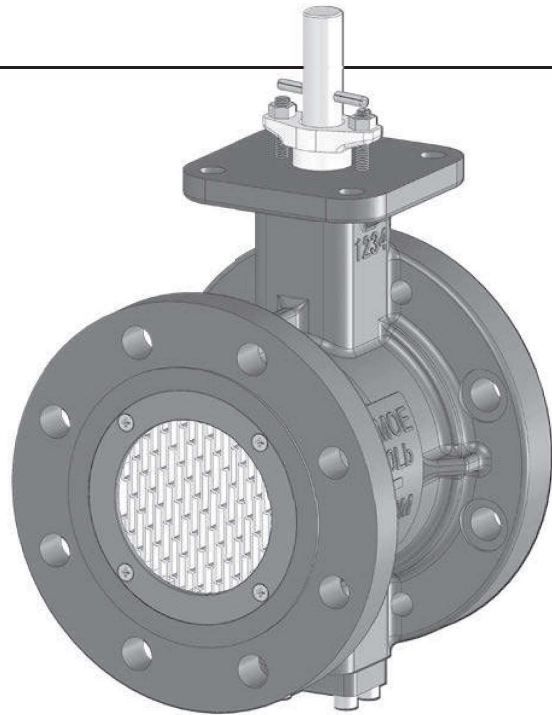
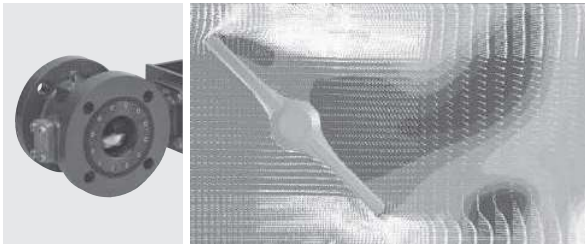

Conventional Butterfly Valve
Local static pressure drop and quick pressure recovery causes cavitation



DTM Series

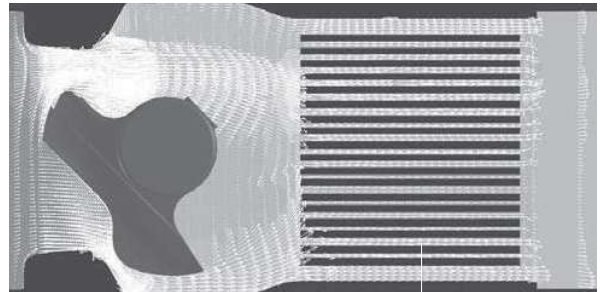
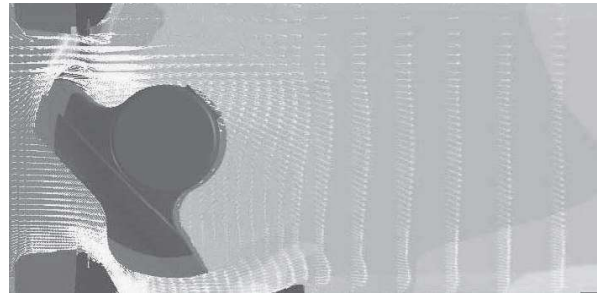

Cavitation breaker

(Note) Colors show the pressure distribution. Red means a high pressure and blue means a low pressure.

Features and Benefits

The ultimate rotary control DTM valve provides accurate control and low noise levels, even at high velocities.

Wide rangeability, 125:1

Improves flow control with a wide range of control from closed to fully open.

Noise reduction by 20dB or more

Features the latest anti-cavitation technology pioneered by TOMOE that delivers superior control and low turbulence in the line. As a result, there is a 20dB reduction in flow induced valve noise and associated damage to piping and equipment compared to conventional valves.

Can handle high differential pressure

Capable of handling extremely high differential pressure with control in the opening range of 0 – 30% and differential pressures greater than 2MPa.

High performance seat structure

Excellent durability and high performance characteristics achieved with metal seat design. Seat leakage of Class V and Rate A for a soft seal.

Ease of maintenance

Designed for easy maintenance – for example, seat and cavitation breaker can be replaced simply and quickly.

High performance diaphragm actuator

A new high performance diaphragm pneumatic actuator that is compact, highly accurate and has proven long life in the field has been designed to manage the DTM valve actuation process with optimum efficiency.

Optional RPTFE seat

The DTM is also available with an RPTFE seat which provides zero leakage to ISO 5208 Rate A.

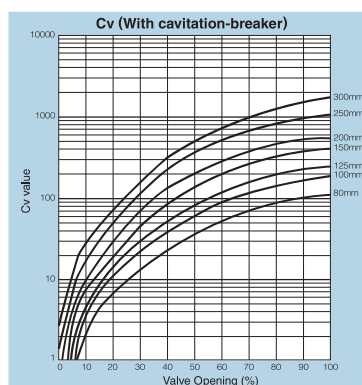
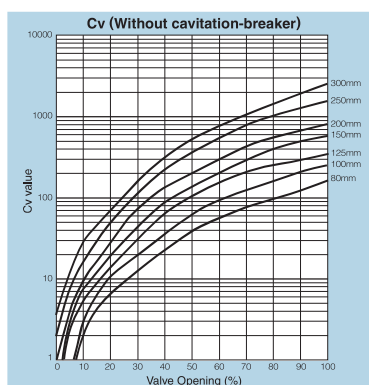
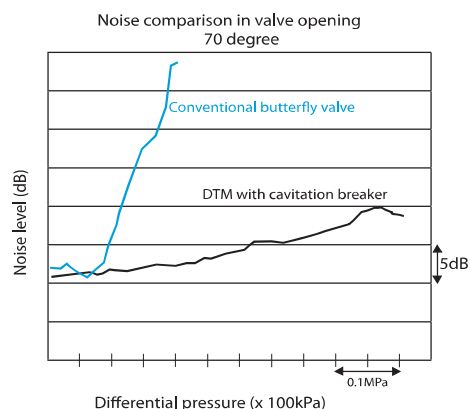

Standard Specifications

Valve type	Rotary control butterfly valve (with low noise characteristics)			
Valve nominal size	80, 100, 125, 150, 200, 250, 300mm			
Pressure rating	ASME B 16.5 Class 150, 300			
Flange accommodation	JIS10, 16, 20, 30K, ASME B 16.5 CLASS 150, 300			
Body Style	Double flanged			
Face-to-face dimensions	IEC 60534-3-2 (JIS B 2005-3-2)			
Flow characteristics	Equal percent, CV linear (option)			
Rangeability	With cavitation breaker 100:1 Without cavitation breaker 125:1			
Flow direction	Flow to retainer side			
Max. working pressure / Closed	Class 150 : 2MPa / Class 300 : 5.1MPa			
Max. differential pressure / Open by 30%	Class 150 : 0.8MPa / Class 300 : 2MPa			
Seat leakage	ASME B 16.104 / FCI 70 - 2 Class V	ISO 5208 Rate A (Zero leakage)		
Temperature range	-29 to 400 degrees C		-10 to 230 degrees C	
Standard materials	Body	WCB or CF8M		
	Disc	CF8M		
	Stem	Stainless steel 630		
	Seat ring	Stainless steel 316	RPTFE	
	Grand packing	Graphite		
Applicable gaskets	-Seat gasket Any standard seat gasket is applicable. -Spiral gasket ASME flange: Standard spiral gasket with inner & outer lings is applicable. JIS flange: Tomoe original spiral gasket is applicable.			
Actuator	Manual gear, diaphragm actuator, pneumatic cylinder, motorised			

*It is possible that seat leakage occur when fluid (e.g. powder and/or liquid) is solidified by working temperature and other cause. Consult us.

Please note that use with vertical line such as bottom area of discharge spout of hopper, and tank.

*Flange outer diameter and thickness may differ from standard dimensions.

Butterfly
Valve

TRITEC

TT2

334A

344Q

302A/303Q

304A/304Q

304YA

302Y/304Y

304M
(HLV)

507V/508V

DTM

846T/847T/847Q

841T/842T

700Z

700G/704G/705G

72WG/72SG/72LG

731P/732P/
732Q/752W

731R

700E/700K/700S

704G/722F/720F

227P

907T/908H
(MKT)

903L/901C/
905C (Bata-check)